

TACHOMETER PULSE OUTPUT OPTION:

An NPN Tachometer pulse output is available for connecting to a digital tachometer display or PLC.

- One 10ms output pulse per revolution.
- 24VDC, 25mA maximum load (note 1K internal resistor).
- Wire as either a SINK (NPN) or SOURCE(PNP) output. SOURCE requires an external resistor: >2.2K typical

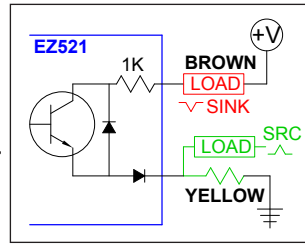

RS-485 DATA OUTPUT OPTION:

Modbus ASCII data is available for PLCs, or, "MaxiScan data" for PC based monitoring.

- **MaxiScan Monitoring Software:** RS-485, 9600 Baud*, N-8-1.
- **Modbus ASCII:** 9600 Baud*, N-8-1 (See Data Sheet)

Modbus ASCII Registers: Function 03 - Holding register

00 01	Current % Speed
00 02	Device Status
00 03	Alarm Speed
00 04	Target Counter
00 05	EZ521 ID. Change the ID using Function 06

Status Codes: 0=Start-up, 1=Armed (Running >90%), 2=10% Trip, 4=20% Trip, 8=5-Second "no motion" trip, 16=Slowed during startup, 32=90 Second T/O exceeded, 64=Not calibrated, 128=Motor is stopped.

*NOTE: Use the "EZ521 Programmer" software to re-program the EZ521 settings.

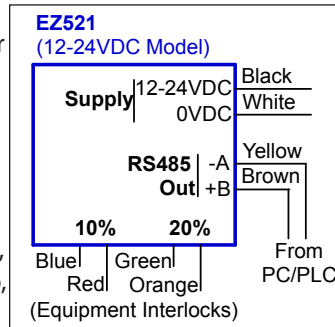

EZ521 MODELS AND SPECIFICATIONS:

EZ521 with Tachometer Output:

- Model Number: 945.000521, complete assembly (945.100521, sensor only)
- Tachometer Output: 15ms pulse output. 30VDC, 50mA max: NPN sinking
- Supply voltage: Universal Supply: 12V-240V AC/DC, 50/60Hz, 100mA
Supply must be fused by installer, 5A Max.

EZ521 with RS485 Data Output: Modbus ASCII and MaxiScan PC Software

- Model Number: 945.000522, complete assembly (945.100522, sensor only)
- Serial Data Output: % speed and status codes are sent over RS-485
- Supply voltage: 12V-24V DC, 100mA. Supply must be fused by installer, 5A Max.

Common Specs:

Wiring: 6 feet, 8 conductor, 20 AWG, type CMG or PLTC
Relays: (2) N/O: One for 10% and one for 20% slowdowns. Dry Contacts.
Relay Contact Rating: 3A@240VAC, 3A@30VDC: **RESISTIVE LOADS ONLY.** Must de-rate and protect contacts (QuenchArc® snubber, MOV) for inductive loads.
Inductive loads and burnt contacts void the warranty.

Speed Range: 8-1000 PPM (targets-per-minute)

Mounting Thread: 1/2"-13 male threads

5/8" wrench flats

EZMount Magnet: 1.9" Diameter x .5"H (optional)

Conduit Fitting: 1/2" NPT Conduit fitting

Assembly Dimensions: 6 3/4"H x 2 1/2"W x 1 3/4"D

EZ521

Underspeed Detection Motion Controller

EZ521 Installation Manual

GENERAL DESCRIPTION:

EZ521 is a shaft mounted, underspeed detection motion controller. Dual set-points provide relay outputs at 10% and 20% slowdowns, a Target LED provides visual indication of shaft rotation and a Status LED provides the operating status.



US
Class II., Div1
Groups E, F, G

THE EZ521 ADVANTAGE:

- CSA Certified Controller: Class II, Div 1 Groups E, F, G
- 10% Slowdown Relay: Closes at 10% slowdown.
- 20% Slowdown Relay: Opens at 20% slowdown.
- Advanced start-up monitoring and protection.
- Easy one-step calibration.
- Easy one-step TEST MODE for full system verification.
- Status LED and Target LED rotation indicator.
- Tachometer pulse output option (NPN Sinking).
- Modbus ASCII and MaxiTrack data outputs for PLC/PC interface.
- Universal supply voltage 12V-240V AC/DC for the TACH model.
- EZ-Mount magnetic mount or 1/2"-13 threaded shaft options.



INCORPORATED 417 Wards Corner Rd., Loveland, OH, 45140 513-398-2500 800-659-8250
Maxi-Tronic Inc. 417 Wards Corner Rd. Loveland, OH 45140 513-398-2500
www.maxitronic.com info@maxitronic.com

MT1003C 1/29/2020

WIRING: All wiring must be in accordance with wiring methods of the National Electrical Code and with the authority having jurisdiction. Prior to installation or repair disconnect power at source following lockout procedures per ANSI Z244.1.

☞ **Supply must be fused for 5A max.**

The EZ521 can be wired so that it only receives power when the Start button is pressed (the monitored equipment is running); stopping the equipment removes power from the EZ521. The EZ521 can also be wired to receive power all the time.**

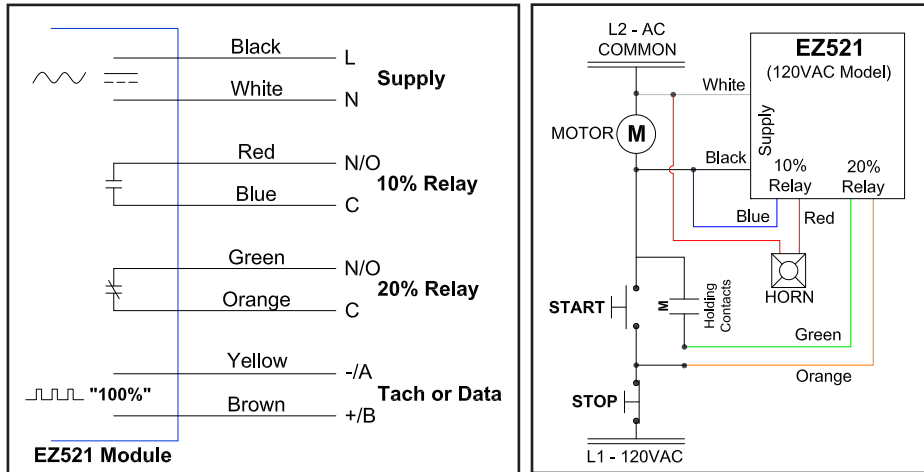

*Relay states shown here are with power applied and equipment running at normal (>90%) speed. Typical 120VAC wiring with 10% Alarm and 20% shutdown interlock.

CALIBRATION:

☞ **You must calibrate the EZ521 for proper operation and protection.**

To Install and Calibrate the EZ521:

1. Install the EZ521 by attaching (thread or magnet) it to the end of the rotating shaft of the monitored equipment.
2. Wire the EZ521 per these installation instructions.
3. Start the equipment and allow it to come up to full normal operating speed. If the EZ521 shuts down the equipment before coming up to speed, see below*.
4. Swipe the yellow Calibration Magnet across the CALIBRATE label on side of unit.
5. The Status LED will flash Green 3 times to indicate a successful calibration.
6. 80% and 90% alarm set-points are recalculated based on the new calibration.

* It may be necessary to “Factory Reset” the EZ521 if it is calibrated for too high of a speed and it doesn’t allow your equipment to come up to full speed before shutting it down.

FACTORY RESET THE CALIBRATION:

To RESET the EZ521 simply calibrate it at zero speed. Do this with the motor not running, or with the EZ521 removed from the shaft.

This procedure resets the calibration to 10RPM.

☞ **You must then perform a valid Calibration for proper operation and equipment protection.**

ALARM FUNCTIONS:

EZ521 provides dual setpoint underspeed detection with dual relay outputs.

EZ521 provides advanced startup sequence protection of the following conditions:

- “Start-up Delay”: No motion detected within 5-10 seconds from start: 8-20RPM=10 second max. delay, >20RPM = 5 second max. delay
- “Slowdown”: Any slowdown detected before reaching 90% speed.
- “Max. Time-Out”: 180 second maximum time limit to reach 90% of full speed.

After reaching normal operating speed:

- 10% Slowdown: Relay #1 closes to sound an alarm.
- 20% Slowdown: Relay #2 opens to shut down the monitored equipment.

☞ **** Startup protection begins when power is first applied to the EZ521.**

☞ **** Note, if the EZ521 is wired to receive power all the time:** When the motor is fully stopped and the EZ521 detects new motion (the Start button is pressed), the “startup sequence protection” automatically begins and the 20% Relay closes.

Function	Description	10% Relay	20% Relay	Status LED
No Power	Equipment not running	Open	Open	No LEDs lit
Apply Power **	Startup sequence begins **	-	Closes	Flash Red, Green once
Not Calibrated	EZ521 is not calibrated (RESET)	-	-	Alternates Red - Green
Calibrate OK	Swipe magnet to calibrate EZ521	-	-	3 rapid Green flashes
Ramping Up	Equipment comes up to speed	-	-	Flashes Green: 1 Sec.
Start-Up Delay	No Motion within 5-10 seconds	-	Opens	*Flashes Red: 2 sec.
Slowdown Trip	Slowdown before reaching 90%	-	Opens	*Flashes Red-Orange
Max Time-Out	Failure to reach 90% in 180 sec.	-	Opens	*Orange
Normal	Normal operation: Speed > 90%	-	-	Green
10% Slowdown	10% relay close, Sounds alarm	Closes	-	Flashes Red: 1 sec.
20% Slowdown	Equipment shutdown	Opens	Opens	*Red
Target LED	Rotation indicator	-	-	Target LED flashes Red

Note: The horn automatically silences (10% Relay opens) when the motor is fully stopped. * 20% Relay Opens: The monitored equipment will shut down at this point. If Power to the EZ521 is disconnected at this time then the Status LED will no longer light. “-” Indicates the relay does not change state for this function.

TEST MODE: ☞ Simulates equipment slowdown to verify system alarms and interlocks. Run this with the leg running at 100% and empty.

1. Hold calibration magnet on CALIBRATE point for 3 seconds.
2. After 3 seconds the EZ521 will enter TEST MODE: It is now in TEST MODE.
3. A very brief green flash of the Status LED will let you know it is in TEST MODE.
4. Starting at 100% the simulated speed will drop by 2% per second.
5. The 10% alarm (5 seconds into the test) and 20% (10 seconds) alarms will trip.
6. After 15 seconds the TEST MODE will end and normal operation will resume.