

INSTALLATION:

Track (align) belts and pulleys prior to installing BeltTracker sensors.

Sensors should be installed in pairs (one on each side) on the upside of the belt at "noon" or "9 o'clock" on the head and at "9 o'clock" on the boot.

1. Mark the location on the outside of the casing where the belt/pulley would contact the center of the stainless steel sensor disc.
2. Drill a 2-3/4" hole centered at that location. Center the BeltTracker disc in the drilled hole and mark the location of the 4 outer mounting holes.
3. Drill the 4 mounting holes in the casing. Use 3/16" diameter stainless rivets to mount the BeltTracker assembly to the casing.
 - Use the optional 1/8" neoprene mounting gasket if needed.
4. Attach appropriately rated conduit to the integral conduit fitting on the BeltTracker and connect to a junction box located within 10'.

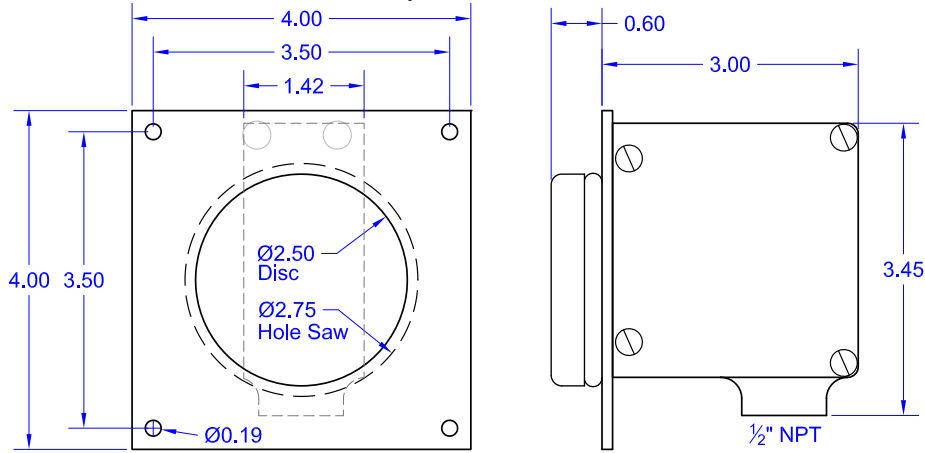

SPECIFICATIONS:

Switch Contact Rating: AC: 5A at 125VAC/250VAC 50/60Hz, Non inductive
DC: .5A at 125VDC, .25A at 250VDC

Factory Wiring: 10' Type SJO 18/3 cable wired to N/C (or N/O) and COM terminals. Specify N/O when ordering.

CSA Rated Temperature: -13F to 130F (-25C to 55C)

Absolute Temperature: -20F to 176F (80C)

Conduit Connection: Integral 1/2" NPT conduit fitting

Dimensions: 4"H x 4"W x 3-5/8"D. 3" mounting depth.

Mounting Holes: 4 holes, 3/16" diameter. 3-1/2" x 3-1/2" spacing.

Shipping Weight: 3 pounds (1.36 Kg)

Approval: CSA certified Class II, Division 1, Groups E, F, G

MAXI-TRONIC
INCORPORATED

417 Wards Corner Rd., Loveland, OH, 45140

513-398-2500

800-659-8250

Maxi-Tronic Inc. 417 Wards Corner Rd. Loveland, OH 45140 513-398-2500
www.maxitronic.com info@maxitronic.com

BeltTracker™

Belt Misalignment Limit Switch

Installation Guide

GENERAL DESCRIPTION:

BeltTracker belt misalignment sensors are ideal for bucket elevators, belt conveyors, rotary drums, and other food processing and material handling equipment.



US
Class II, Div. 1
Groups E, F, G

The BeltTracker Advantage:

- Models: N/C: 948.000720, N/O: 948.000722, 1" Disc N/C: 948.000721
- Near-instant sensing of belt contact
- N/C and N/O momentary output contacts, latching optional
- Contact rating: 5A at 125VAC/250VAC 50/60Hz, .5A at 125VDC, .25A at 250VDC
- Approved dust-ignition proof construction: CSA Class II, Div 1
- Not affected by dust buildup
- Stainless steel abrasion resistant sensor disc, replaceable
- Heavy duty design, minimal moving parts.
- Easily test the electrical switch and the mechanical operation
- Integral 1/2" conduit fitting
- No power supply needed

MAXI-TRONIC
INCORPORATED

417 Wards Corner Rd., Loveland, OH, 45140

513-398-2500

800-659-8250

Maxi-Tronic Inc. 417 Wards Corner Rd. Loveland, OH 45140 513-398-2500
www.maxitronic.com info@maxitronic.com

MT101B 1/2020

WIRING:

All wiring must be in accordance with wiring methods of the National Electrical Code and with the authority having jurisdiction.

Prior to installation, inspection, calibration, or repair, disconnect power at source following lockout-tagout procedures per ANSI Z244.1.

The BeltTracker switch is factory wired with 10-feet of 18/3 SJO cable:

- The Black conductor is factory wired to the COM terminal.
- The White conductor is factory wired to the N/C (or N/O) terminal.
- The Green conductor is bonded to the BeltTracker housing.

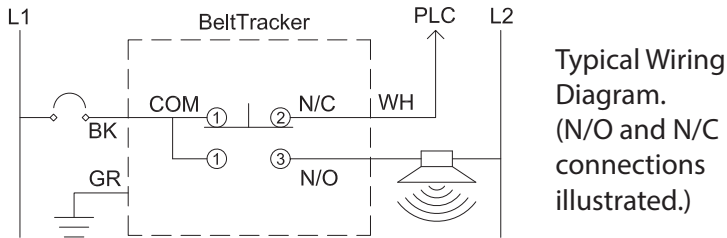

☞ **If you remove or loosen the internal switch, you must re-calibrate the sensitivity of the unit.**

SENSITIVITY ADJUSTMENT - CALIBRATION:

BeltTracker units are factory calibrated to trip at approximately 10-15 pounds of force. Sensitivity adjustment is easiest prior to installation but can be adjusted after installation. Must be performed by a qualified technician.

Adjust the trip-force by turning the adjustment screw until the switch trips and then backing it off a predetermined amount:

1. Remove the lid. Be careful not to damage the gasket.
2. Loosen the Lock-Nut on the Adjustment Screw (see illustration next page).
3. Turn the Adjustment Screw clockwise (screwing it into the Spindle) until it no longer contacts the switch plunger.
4. Turn the Adjustment Screw counter-clockwise (unscrewing it from the Spindle) just until the Switch clicks (trips).
5. Slowly turn the Adjustment Screw clockwise (screwing it into the Spindle) until the Switch clicks (un-trips). Continue turning clockwise for 1/6th turn. This sets the sensor to trip at approximately 15 pounds of force.
6. If a more precise adjustment is required: Place the BeltTracker sensor Disc-side down on an accurate scale. Press on the unit and while watching the scale and adjust the adjustment Screw to trip at a specific force.
7. Place a reference mark to mark the position of the Adjustment Screw.
8. Tighten the Lock-Nut without letting the Adjustment Screw turn. Recheck.
9. Reattach lid. Tighten lid screws (w/lock washers) to 15 inch-pounds torque using a criss-cros pattern. Then, tighten only the 2 lid screws that are nearest the Mounting Plate to 25 inch-pounds.

WARNING, EXPLOSION HAZARD:

- ☞ **High Voltage may exist in the BeltTracker housing.**
- ☞ **Do not wire sensor until power has been removed.**
- ☞ **Do not run BeltTracker wiring in conduit with low voltage wires.**
- ☞ **Do not use BeltTracker for direct motor control.**

FUNCTION:

- ☞ **BeltTracker is a momentary push-button switch; the output is voltage-free and is not latched.**
 - BeltTracker provides a N/C or N/O momentary switch output which changes state when the belt/pulley contacts the front disc with sufficient force.
 - An optional external "Latching Board" is available to provide a latching output for up to 12 sensors each. Use the latching board when connecting to a Maxi-Tronic MTDT24 Temperature Scanner.

TESTING:

Simple testing is performed by pressing on the sensor Disc with your hand. If the unit is mounted such that you cannot press on the Disc:

- 1) Remove the lid. Be careful not to damage the gasket.
- 2) Insert a slotted screwdriver into the groove shown in the figure below.
- 3) Gently twist the screwdriver to cause the sensor Disc to depress and the switch to actuate.
- 4) Reattach lid. Tighten lid screws (w/lock washers) to 15 inch-pounds torque using a criss-cross pattern. Then, tighten only the 2 lid screws that are nearest the Mounting Plate to 25 inch-pounds.

To Test: Insert slotted screwdriver and gently twist.

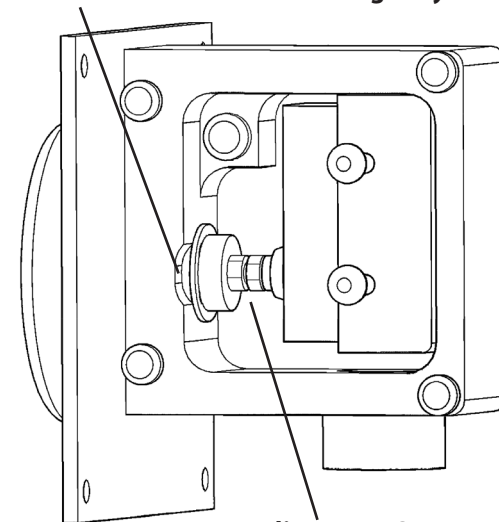

Adjustment Screw and Lock-Nut

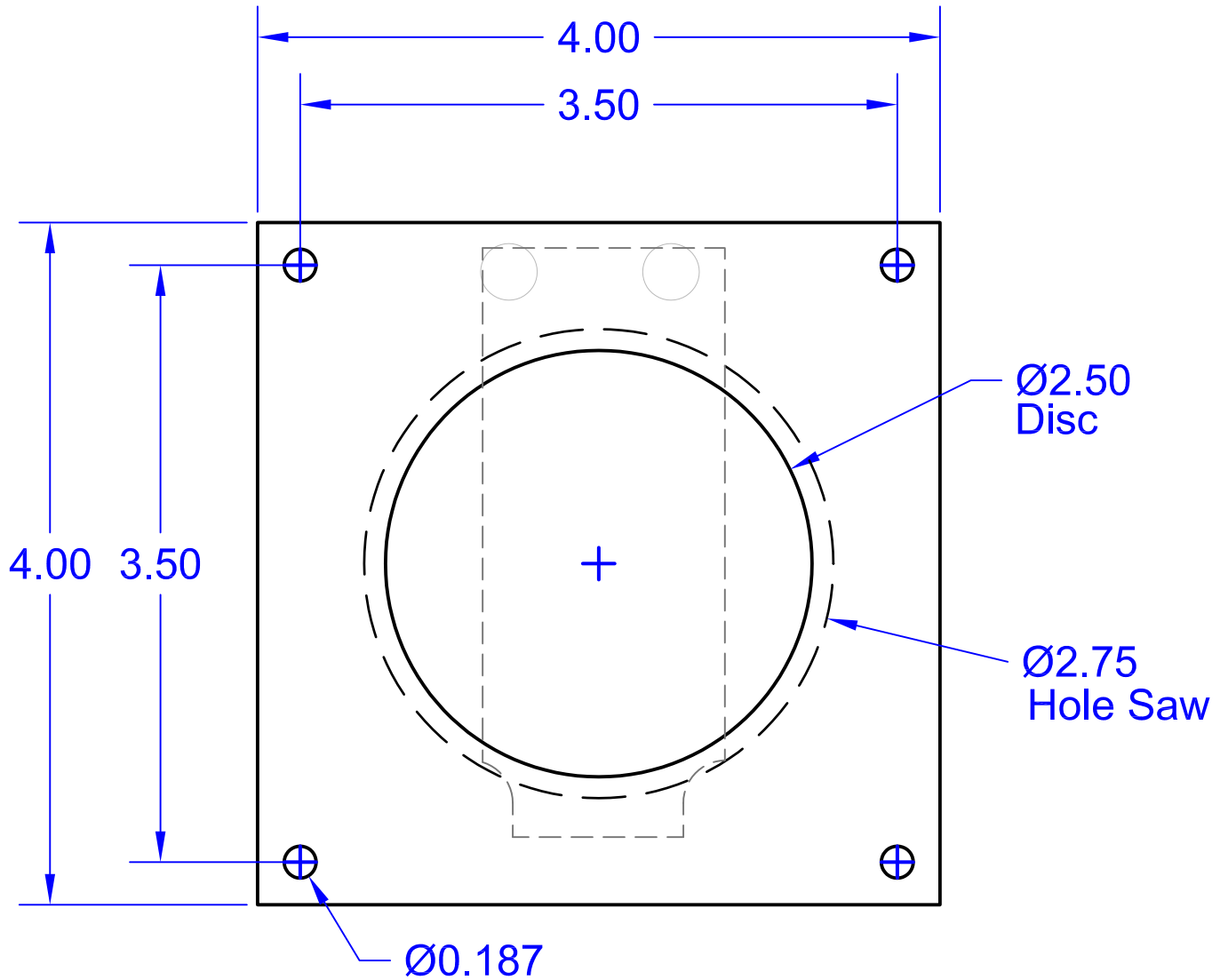

Print this document at "ACTUAL SIZE",
not "FIT" or "SCALE TO PAPER".

MAXI-TRONIC INC. LOVELAND, OHIO 45140			
TITLE: BELTRACKER MOUNTING TEMPLATE 6061-T6 ALUMINUM, TYPE II ANODIZED			
PART NO: 948.000720		DWG NO. A-15-BT-MT	REV: 1
SCALE:	SIZE:	DRAWN BY: JTL	DATE: 11-24-2015