



MT 300 SERIES MOTION SENSOR

INSTALLATION & TECHNICAL MANUAL

**MAXI-TRONIC
3530 IRWIN SIMPSON ROAD
MASON, OH 45040
800.659.8250 FAX: 513.398.2536**

www.maxitronic.com

MT-300 MOTION SENSOR AND CONTROL WIRING

ARM CIRCUIT

When Starter switch is energized:

1. 117VAC is supplied to the ARM terminal:
 - a) This voltage should be supplied to the arm terminal from the time the Start switch is energized until the Stop switch is energized.
 - b) Arm voltage must be 90 to 130 VAC only. Any other voltage will result in the motion sensor not working and/or damage to the motion sensor.
 - c) Arm voltage when being read on a voltmeter, must be read using AC Common supplied to the motion sensor input voltage as AC Common.

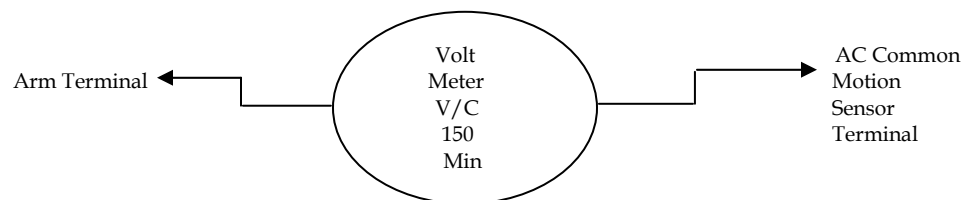

If this voltage is approximately $\frac{1}{2}$ voltage (50 to 60 VAC), it means that the leg starter voltage and the motion sensor AC Common are not of the same phase and the ARM circuit will not function.

2. With proper ARM voltage:
 - a) Starter switch is energized.
 - b) Motion sensor arm terminal will sense arm voltage (117VAC).
 - c) The arm:- 10%-20% indicators located on the motion sensor display will go from indicators "on" (illuminated) to indicators "off" (no illumination).
 - d) Relays will be heard on the motion sensor PC Board - switch to the run position.
 - e) Target indicator on the motion sensor display should start to flash "on" and then "off" for each target that passes by the front of the motion sensor probe.
3. The equipment accelerates to operating speed:
 - a) With the target light flashing, the tachometer (percent of operating speed) should start to move upward (toward the right).

- b) When the tachometer reaches approximately 90% on the scale, the arm indicator should light.
- c) The tachometer should continue to increase (move to the right) until it reaches 100%.

RELAY OUTPUTS

10% Relay Contacts:

- Note: Relay contacts on the wiring diagram are shown with 117VAC supplied to the motion sensor and leg *not* operating. This is also the relay state when the equipment is operating normally at full speed.
- The 10% relay contacts operate when the equipment reduces speed 10% below normal operating speed.
- Contact Rating: 5 Amp at 220 VAC
- Relay contacts are “dry” (no internal voltage).
- Contacts can be used to start or stop auxiliary equipment. To turn on alarm system, etc. See drawings A & S-01A, B, and C on pages 7,8 and 9.

20% Relay Contacts:

- Note: Relay contacts on the wiring diagrams are shown with 117 VAC applied to the motion sensor and the equipment *not* operating. This is also the relay state when the equipment is operating normally at full speed.
- The 20% relay contacts operate when the equipment reduces speed 20% below normal operating speed. The function of the 20% contacts are:
 - to shut down the equipment.
 - to energize auxiliary relay(s) for sequence shut down of other equipment.
- Contact Rating: 5 Amp at 220 VAC
- Relay contacts are “dry” (no internal voltage). The voltage *connected* to the relay common 20% will be the output voltage at the N/O (normally open) N/C (normally closed) 20% contacts.
- When the 20% indicator on the motion sensor display is on” (light), there will be contact between Common and N/C terminals. There will be *no* contact between Common and N/O contacts.
- When the 20% indicator is *not* illuminated, there will be contact between Common and N/O terminals. There is no contact between Common and N/C. See page 9 drawing A & S-01B and pages 8 and 9 A & B-01B & C.
- When the start button is energized:
 - a) Arm voltage will appear at the arm terminal at the motion sensor.

- b) Relays in the motion sensor will change state.
- c) The 20% Relay Common and N/C contacts will now close.
- d) This will allow the starter relay to energize and allow the equipment to operate.

Note: Remember if the 20% indicator is *on*, the relay contacts will be open and the equipment will not operate.

TROUBLE SHOOTING

Motion sensor shuts equipment down after approximately three (3) seconds:

Check to see that the target light flashes on and off with rotating target disc on the boot shaft or the moving buckets when monitoring bucket bolts.

1. If the target light does not flash:
 - a) Remove the probe from the mounting bracket;
 - b) Move the metal target (screwdriver etc.) across the front of the probe approximately ½ inch away from the probe;
 - c) Go to the section "Target Light Either Stays On/Off" and perform checks.
2. If the target light flashes:
 - a) Check for metal too close to the probe (no metal, leg casing, bearing, housing, etc. should be within 2 inches of the probe).
 - b) Check calibration and see "Motion Sensor Calibration" section.

Motion sensor will not allow equipment to start:

1. No or improper ARM voltage (see "Arm Circuit" section, page 1)
2. 20% leg shut down contacts are not properly connected (see section "20% Relay Contacts").

Motion sensor will not allow auxiliary equipment or conveyors connected to the 20% function to operate:

Shut-down contacts at the 10% relay are not connected properly (see section "10% Relay Contacts").

Target light either stays on or off at all times:

1. The motion sensor cable is not connected properly.
Check at the motion sensor terminal block that:

- a) Wire colors from the probe cable match colors at terminal strip.
 - b) Wire conductors are making contact on the terminal.
 - c) Insulation on the wire is not caught under the terminal.
2. Conductors in the probe cable are shorted.
To check for shorted conductors:
- a) Disconnect the probe cable at the motion sensor terminal and disconnect the probe.
 - b) Using a OHM meter to read continuity:
 - Read from the Green conductor; there should be no continuity to the White or Black conductor.
 - Read from the Red conductor; there should be no continuity to the White or Black conductor.
 - There should be no continuity between the Black or White conductor. (Note: Red-Green-Shield (if used) are all common to each other. There would be no problem having continuity between any of these conductors.)
 - If you read continuity between conductors that should *not* have continuity:
 - remove probe connector metal housing;
 - clean connector solder joints and pins with a electronic component cleaner (such as tuner cleaner);
 - recheck for continuity (see above).

Note: If after replacing probe connector metal housing, the cable fails continuity test, there is contact between soldered conductor and metal probe connector housing. Check and resolder conductors making sure not to over-use amount of solder or it will short the connector to the cover. Then repeat above step.

3. Conductors in the probe cable are open.
Make sure the probe connector cable is disconnected at the motion sensor terminal strip end of the probe cable. At the terminal strip end:
- a) Twist Red-Green-Shield together. Be sure conductors are making contact. At the probe connector end of the probe cable, using the OHM meter, check for continuity between the Green and Red conductors at probe connector. There should be continuity.
 - b) Repeat step a) with the Black and White conductors connected. If the cable fails these tests, excluding the probe connector housing being shorted out, replace the probe cable.

4. If the probe cable checks OK and there is still a problem with the target indicator:
 - a) Reconnect the probe cable to the motion sensor terminal strip, and reconnect the probe to the probe cable.
 - b) Using a DC voltmeter:
 - Read voltage from Red or Green (- DC) to White (+ DC) conductors. This voltage should be 12 VDC +/- 5%.
 - Read voltage from Red or Green (- DC) to Black (+ DC) conductors. This should read between 4 to 7 + DC.
 - c) If the above voltages are not within tolerance, check to be sure there is no metal (leg casing, bearing housing, etc.) within two (2) inches of the probe.
 - d) If step 3 is correct, replace the probe.
 - e) If all the tests are correct but there is still no target light, replace the PC board.
 - f) If the equipment is started and the motion sensor allows the equipment to operate:- if the tachometer moves to the right and all other motion sensor functions seem correct, check the target indicator. This is a LED and normally it will last the life of the motion sensor. Check for broken leadwire or a leadwire shorted to housing. Repair or replace as needed.

MOTION SENSOR CALIBRATION

1. Turn calibration control (located with the motion sensor display) fully clockwise.
2. Start the equipment to operating.
3. After the equipment is at full operating speed, start turning the calibration control counter clockwise in small increments until % tachometer reads 100%. NOTE: There is a short delay between the activation of the equipment and the tachometer displays. This delay is to take care of the normal deviations of equipment operation (power fluctuations, etc.) When calibrating, please allow the tachometer to stabilize before moving to the next increment.
4. If the tachometer does not move above 100% when fully clockwise, there are not enough targets passing the probe. The standard PC board is designed for a range of 200 to 1000 targets per minute.

- When increasing the number of targets using a target disc, the targets must be evenly spaced on the disc.
 - If monitoring the leg buckets, please contact Maxi-Tronic to get a slower speed PC board.
5. If calibration control will not bring the tachometer below 100%, there are too many targets passing the probe.
- If using a target disc, remove the targets. The targets must be evenly spaced on the disc.
 - If monitoring the leg buckets, please contact Maxi-Tronic to get a higher speed PC board.

Typical Equipment Interlock Wiring Diagram:

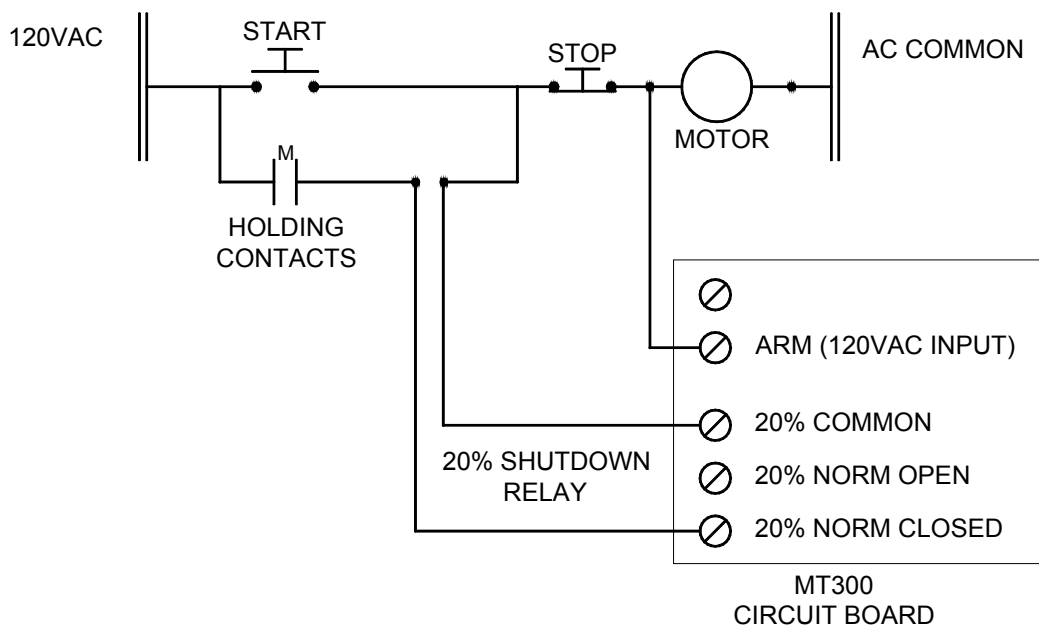

MT MOTION SENSOR TEST PROCEDURES

IMPORTANT: The motion sensor pickup probe is a metal detection device. ANY metal within 1-1/2" of the probe will interfere with the signal.

To Test MT Motion Sensors In The Field:

1. Start Monitored Equipment to operating. With NO load:

Check motion sensor for the following:

- Target indicator should be flashing for each target that passes by probe.
- Percent meter should move upward and read 100%.
- The Arm Indicator should be lit.
- 10% Indicator should not be lit.
- 20% Indicator should not be lit.

2. Turn the calibration control fully counter-clockwise and check for the following:

- Percent meter should start to drop (decrease).
- When percent meter drops (decreases) to 90%:
 - 10% Indicator will turn ON.
- If Alarm installed: Alarm should now be energized.
- If equipment is connected to the 10% relay for shut down-equipment will shut down.

When percent meter drops (decreases) to 80%:

20% Indicator will turn **ON**

Note: If equipment is connected for shut down at 20%-Reduction of speed then equipment will shut down and alarm will shut off.

3. Recalibrate Motion Sensors:

Turn calibration control full clockwise

Start monitored equipment to operating

Percent meter should go above 100%

4. Perform the following **without load** on monitored equipment:

Slowly turn calibration control counter-clockwise until percent meter reads 100%.

Motion sensor is now ready for normal operation.

**IF ANY PART OF THIS TEST PROCEDURE DOES NOT OCCUR, CONTACT
MAXI-TRONIC AT 800-659-8250.**